

LineLazer™ 130HS Airless Paint Striper

313776G

EN

For application of line striping materials. For professional use only. Not for use in explosive atmospheres.

3300 psi (22.8 MPa, 228 bar) Maximum Working Pressure

						
257780	✓			✓		
287025	✓	✓	✓			



Important Safety Instructions

Read all warnings and instructions in this manual.
Save these instructions.



313775



309055



311845



311254

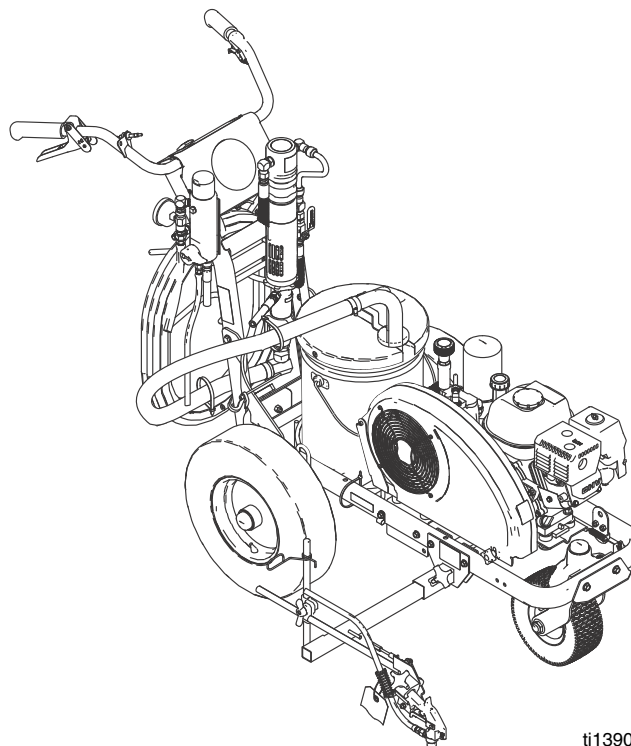

ti13901a















Contents

Warnings	3
Tip Selection	5
General Repair Information	6
Maintenance	7
Troubleshooting	8
Hydraulic Pump	11
Fan Belt	13
Engine	14
Hydraulic Motor Yoke	15
Oil/Filter Change	17
Displacement Pump	18
Parts	19
Technical Data	32
Accessories	32
Notes	33
Graco Standard Warranty	34

Warnings

The following warnings are for the setup, use, grounding, maintenance, and repair of this equipment. The exclamation point symbol alerts you to a general warning and the hazard symbol refers to procedure-specific risk. Refer back to these warnings. Additional, product-specific warnings may be found throughout the body of this manual where applicable.

 WARNING	
	<p>FIRE AND EXPLOSION HAZARD</p> <p>Flammable fumes, such as solvent and paint fumes, in work area can ignite or explode. To help prevent fire and explosion:</p> <ul style="list-style-type: none"> • Use equipment only in well ventilated area. • Do not fill fuel tank while engine is running or hot; shut off engine and let it cool. Fuel is flammable and can ignite or explode if spilled on hot surface. • Eliminate all ignition sources; such as pilot lights, cigarettes, portable electric lamps, and plastic drop cloths (potential static arc). • Keep work area free of debris, including solvent, rags and gasoline. • Do not plug or unplug power cords, or turn power or light switches on or off when flammable fumes are present. • Ground all equipment in the work area. See Grounding instructions. • Use only grounded hoses. • Hold gun firmly to side of grounded pail when triggering into pail. • If there is static sparking or you feel a shock, stop operation immediately. Do not use equipment until you identify and correct the problem. • Keep a working fire extinguisher in the work area.
	<p>CARBON MONOXIDE HAZARD</p> <p>Exhaust contains poisonous carbon monoxide, which is colorless and odorless. Breathing carbon monoxide can cause death. Do not operate in an enclosed area.</p>
	<p>SKIN INJECTION HAZARD</p> <p>High-pressure fluid from gun, hose leaks, or ruptured components will pierce skin. This may look like just a cut, but it is a serious injury that can result in amputation. Get immediate surgical treatment.</p> <ul style="list-style-type: none"> • Do not point gun at anyone or at any part of the body. • Do not put your hand over the spray tip. • Do not stop or deflect leaks with your hand, body, glove, or rag. • Do not spray without tip guard and trigger guard installed. • Engage trigger lock when not spraying. • Follow Pressure Relief Procedure in this manual, when you stop spraying and before cleaning, checking, or servicing equipment.
	<p>PRESSURIZED EQUIPMENT HAZARD</p> <p>Fluid from the gun/dispense valve, leaks, or ruptured components can splash in the eyes or on skin and cause serious injury.</p> <ul style="list-style-type: none"> • Follow Pressure Relief Procedure in this manual, when you stop spraying and before cleaning, checking, or servicing equipment. • Tighten all fluid connections before operating the equipment. • Check hoses, tubes, and couplings daily. Replace worn or damaged parts immediately.

 WARNING	
	<p>EQUIPMENT MISUSE HAZARD</p> <p>Misuse can cause death or serious injury.</p> <ul style="list-style-type: none"> • Do not operate the unit when fatigued or under the influence of drugs or alcohol. • Do not exceed the maximum working pressure or temperature rating of the lowest rated system component. See Technical Data in all equipment manuals. • Use fluids and solvents that are compatible with equipment wetted parts. See Technical Data in all equipment manuals. Read fluid and solvent manufacturer's warnings. For complete information about your material, request MSDS forms from distributor or retailer. • Check equipment daily. Repair or replace worn or damaged parts immediately with genuine manufacturer's replacement parts only. • Do not alter or modify equipment. • Use equipment only for its intended purpose. Call your distributor for information. • Route hoses and cables away from traffic areas, sharp edges, moving parts, and hot surfaces. • Do not kink or over bend hoses or use hoses to pull equipment. • Keep children and animals away from work area. • Comply with all applicable safety regulations.
	<p>BURN HAZARD</p> <p>Equipment surfaces and fluid that's heated can become very hot during operation. To avoid severe burns, do not touch hot fluid or equipment. Wait until equipment/fluid has cooled completely.</p>
	<p>MOVING PARTS HAZARD</p> <p>Moving parts can pinch or amputate fingers and other body parts.</p> <ul style="list-style-type: none"> • Keep clear of moving parts. • Do not operate equipment with protective guards or covers removed. • Pressurized equipment can start without warning. Before checking, moving, or servicing equipment, follow the Pressure Relief Procedure in this manual. Disconnect power or air supply.
	<p>TOXIC FLUID OR FUMES HAZARD</p> <p>Toxic fluids or fumes can cause serious injury or death if splashed in the eyes or on skin, inhaled, or swallowed.</p> <ul style="list-style-type: none"> • Read MSDS's to know the specific hazards of the fluids you are using. • Store hazardous fluid in approved containers, and dispose of it according to applicable guidelines. • Always wear impervious gloves when spraying or cleaning equipment.
	<p>PERSONAL PROTECTIVE EQUIPMENT</p> <p>You must wear appropriate protective equipment when operating, servicing, or when in the operating area of the equipment to help protect you from serious injury, including eye injury, inhalation of toxic fumes, burns, and hearing loss. This equipment includes but is not limited to:</p> <ul style="list-style-type: none"> • Protective eyewear • Clothing and respirator as recommended by the fluid and solvent manufacturer • Gloves • Hearing protection
	<p>RECOIL HAZARD</p> <p>Gun may recoil when triggered. If you are not standing securely, you could fall and be seriously injured.</p>

Tip Selection

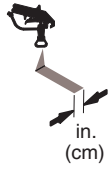
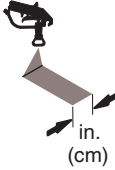
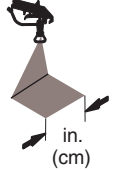
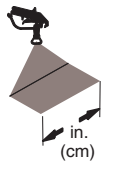
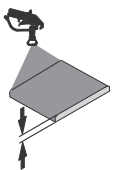
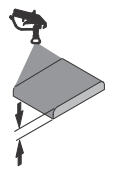
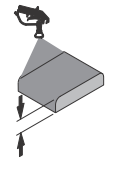
							
LL5213*	2 (5)				✓		
LL5215*	2 (5)					✓	
LL5217		4 (10)				✓	
LL5219		4 (10)					✓
LL5315		4 (10)			✓		
LL5317		4 (10)			✓		
LL5319		4 (10)				✓	
LL5321		4 (10)				✓	
LL5323		4 (10)				✓	
LL5325		4 (10)					✓
LL5327		4 (10)					✓
LL5329		4 (10)					✓
LL5331		4 (10)					✓
LL5333		4 (10)					✓
LL5335		4 (10)					✓
LL5355		4 (10)					✓
LL5417			6 (15)		✓		
LL5419			6 (15)		✓		
LL5421			6 (15)		✓		
LL5423			6 (15)			✓	
LL5425			6 (15)			✓	
LL5427			6 (15)			✓	
LL5429			6 (15)			✓	
LL5431			6 (15)				✓
LL5435			6 (15)				✓
LL5621				12 (30)	✓		
LL5623				12 (30)	✓		
LL5625				12 (30)	✓		
LL5627				12 (30)	✓		
LL5629				12 (30)	✓		
LL5631				12 (30)		✓	
LL5635				12 (30)		✓	
LL5639				12 (30)			✓

* Use 100 mesh filter to reduce tip clogs.

General Repair Information

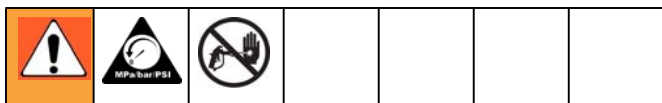

1. **Keep all screws, nuts, washers, gaskets, and electrical fittings** removed during repair procedures. These parts are not normally provided with replacement assemblies.
2. **Test repair** after problem is corrected.
3. **If sprayer does not operate properly**, review repair procedure to verify procedure was done correctly. If necessary, see **Troubleshooting**, page 8, for other possible solutions.



4. **Install belt guard before operation** of sprayer and replace if damaged. Belt guard reduces risk of pinching and loss of fingers.

Grounding

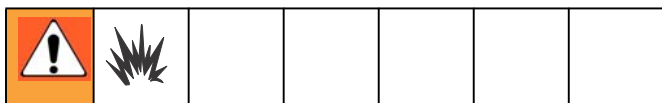

Ground sprayer with grounding clamp to earth ground when flushing sprayer. FIG. 1.

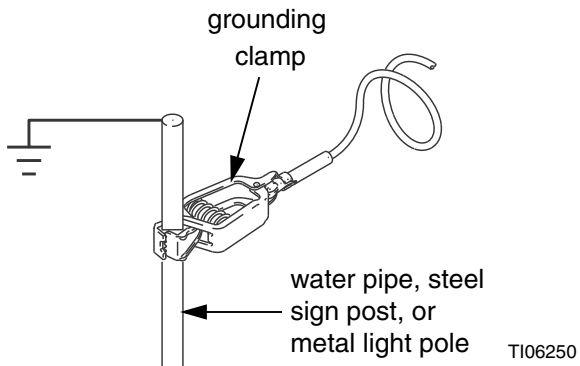
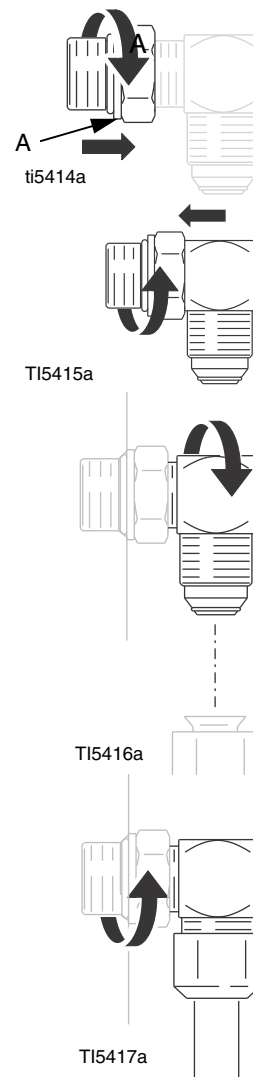

FIG. 1

SAE O-Ring Installation

1. Unscrew lock nut to touch fitting.
2. Lubricate o-ring (A).
3. Screw in fitting hand tight.
4. Unscrew fitting until oriented properly.



5. Tighten lock nut to indicated torque. (Make sure washer is seated properly without pinching o-ring).

Maintenance

Pressure Relief Procedure



1. Engage trigger lock.
2. Turn engine ON/OFF switch to OFF.
3. Move pump valve to OFF (clockwise) and turn pressure control knob fully counterclockwise.
4. Disengage the trigger lock. Hold a metal part of the gun firmly to a grounded metal pail, and trigger the gun to relieve pressure.
5. Engage the trigger lock.
6. Open pressure drain valve. Leave valve open until you are ready to spray again.

If you suspect the spray tip or hose is completely clogged, or that pressure has not been fully relieved after following the steps above, VERY SLOWLY loosen tip guard retaining nut or hose end coupling to relieve pressure gradually, then loosen completely. Clear hose or tip obstruction.

CAUTION

- Minimum hose size allowable for proper sprayer operation is 3/8 in. x 50 ft.
- For detailed engine maintenance and specifications, refer to separate Honda Engines Owner's Manual, supplied.

DAILY: Check engine oil level and fill as necessary.

DAILY: Check hydraulic oil level and fill as necessary.

DAILY: Check hose for wear and damage.

DAILY: Check gun safety for proper operation.

DAILY: Check prime/spray drain valve for proper operation.

DAILY: Check and fill the gas tank.

DAILY: Check that displacement pump is tight.

DAILY: Top off TSL level in displacement pump packing nut to help prevent material buildup on piston rod and early wear of packings.

AFTER THE FIRST 20 HOURS OF OPERATION: Drain engine oil and refill with clean oil. Reference Honda Engines Owner's Manual for correct oil viscosity.

WEEKLY: Remove engine air filter cover and clean element and replace, if necessary. If operating in an unusually dusty environment: check filter daily.

WEEKLY/DAILY: Remove any debris from hydraulic rod.

AFTER EACH 100 HOURS OF OPERATION: Change engine oil. Reference Honda Engines Owner's Manual for correct oil viscosity.

SEMI-ANNUALLY: Check belt wear, page 18; replace if necessary.

YEARLY OR 2000 HOURS: Replace hydraulic oil and filter element with Graco hydraulic oil 169236 (5 gallon/18.9 liter) or 207428 (1 gallon/3.8 liter) and filter element 246173; page 17.

SPARK PLUG: Use only BPR6ES (NGK) or W20EPR-U (NIPPONDENSO) plug. Gap plug to 0.028 to 0.031 in. (0.7 to 0.8 mm). Use spark plug wrench when installing and removing plug.

Caster Wheel

(See letter call-outs in **Parts** drawing on page 19.)

1. Once each year, tighten nut (127, detail A) until spring washer bottoms out. Then back off the nut 1/2 to 3/4 turn.
2. Once each year, tighten nut (127) until it begins to compress spring washer. Then tighten the nut an additional 1/4 turn.
3. Once each month, grease the wheel bearing (F).
4. Check pin (55) for wear. If pin is worn out, there will be play in the caster wheel. Reverse or replace the pin as needed.
5. Check caster wheel alignment as necessary. To align: loosen bolt (145), align wheel and tighten bolt.

Troubleshooting



Problem	Cause	Solution
Gas engine pulls hard (won't start).	Hydraulic pressure is too high.	Turn hydraulic pressure knob counterclockwise to lowest setting.
Engine won't start.	Engine switch is OFF.	Turn engine switch ON.
	Engine is out of gas.	Refill gas tank. Honda Engines Owner's Manual.
	Engine oil level is low.	Try to start engine. Replenish oil, if necessary. Honda Engines Owner's Manual.
	Spark plug cable is disconnected or damaged.	Connect spark plug cable or replace spark plug.
	Cold engine.	Use choke.
	Fuel shutoff lever is OFF.	Move lever to ON position.
	Oil is seeping into combustion chamber.	Remove spark plug. Pull starter 3 to 4 times. Clean or replace spark plug. Start engine. Keep sprayer upright to avoid oil seepage.
Engine operates, but displacement pump does not operate.	Pump valve is OFF.	Turn pump valve ON.
	Pressure setting is too low.	Turn pressure adjusting knob clockwise to increase pressure. Manual 311018.
	Fluid filter (11) is dirty.	Clean filter.
	Tip or tip filter is clogged.	Clean tip or tip filter. Manual 311254.
	Displacement pump piston rod is stuck due to dried paint.	Repair pump. Manual 311845.
	Belt worn, broken or off pulley.	Replace.
	Hydraulic fluid too low.	Shut of sprayer. Add fluid*.
	Hydraulic motor not shifting.	Set pump valve OFF. Turn pressure down. Turn engine OFF. Pry rod up or down until hydraulic motor shifts.

* Check hydraulic fluid level often. Do not allow it to become too low. Use only Graco approved hydraulic fluid, page 7.

Problem	Cause	Solution
Displacement pump operates, but output is low on upstroke	Piston ball is not seating.	Service piston ball. Manual 311845.
	Piston packings are worn or damaged.	Replace packings. Manual 311845.
Displacement pump operates but output is low on downstroke and/or on both strokes.	Strainer (34e) is clogged.	Clean strainer.
	O-ring in pump is worn or damaged.	Replace o-ring. Manual 311845..
	Intake valve ball is packed with material or is not seating properly.	Clean intake valve. Manual 311845..
	Engine speed is too low.	Increase throttle setting. Manual 313775.
	Suction tube air leak.	Tighten suction tube.
	Pressure setting is too low.	Increase pressure. Manual 313775.
	Fluid filter (11), tip filter or tip is clogged or dirty.	Clean filter. Manual 313775 or 311254.
	Large pressure drop in hose with heavy materials.	Use larger diameter hose and/or reduce overall length of hose. Use of more than 100 ft of 1/4 in. hose significantly reduces performance of sprayer. Use 3/8 in. hose for optimum performance (50 ft minimum).
Pump is difficult to prime.	Air in pump or hose.	Check and tighten all fluid connections. Reduce engine speed and cycle pump as slowly as possible during priming.
	Intake valve is leaking.	Clean intake valve. Be sure ball seat is not nicked or worn and that ball seats well. Reassemble valve.
	Pump packings are worn.	Replace pump packings. Manual 311845.
	Paint is too thick.	Thin the paint according to the supplier's recommendations.
	Engine speed is too high.	Decrease throttle setting before priming pump. Manual 313775.
High engine speed at no load.	Misadjusted throttle setting.	Reset throttle to 3700-3800 engine rpm at no load.
	Worn engine governor.	Replace or service engine governor.
Low stall or run pressure shown on display.	New pump or new packings.	Pump break-in period takes up to 100 gallons of material.
	Faulty transducer.	Replace transducer.
Excessive paint leakage into throat packing nut.	Throat packing nut is loose.	Remove throat packing nut spacer. Tighten throat packing nut just enough to stop leakage.
	Throat packings are worn or damaged.	Replace packings. Manual 311845.
	Displacement rod is worn or damaged.	Replace rod. Manual 311845.
Fluid is spitting from gun.	Air in pump or hose.	Check and tighten all fluid connections. Reprime pump. Manual 313775.
	Tip is partially clogged.	Clear tip. Manual 311254.
	Fluid supply is low or empty.	Refill fluid supply. Prime pump. Manual 313775. Check fluid supply often to prevent running pump dry.

Troubleshooting

Problem	Cause	Solution
Excessive leakage around hydraulic motor piston rod wiper.	Piston rod seal worn or damaged.	Replace these parts.
Fluid delivery is low.	Pressure setting too low.	Increase pressure. Manual 313775.
	Displacement pump outlet filter (if used) is dirty or clogged.	Clean filter.
	Intake line to pump inlet is not tight.	Tighten.
	Hydraulic motor is worn or damaged.	Bring sprayer to Graco distributor for repair.
	Large pressure drop in fluid hose.	Use larger diameter or shorter hose.
The sprayer overheats.	Paint buildup on hydraulic components.	Clean.
	Oil level is low.	Fill with oil, page 7.
Excessive hydraulic pump noise.	Low hydraulic fluid level.	Shut off sprayer. Add fluid*, page 7.

Hydraulic Pump

Removal



1. Allow hydraulic system to cool before beginning service.
2. Relieve pressure, page 7.
3. Place drip pan or rags under sprayer to catch hydraulic oil that leaks out during repair.
4. Remove drain plug (195) and oil filter (199) and allow hydraulic oil to drain.
5. Remove screw (224), loosen belt guard knob (241) and belt guard (24).
6. Raise motor and remove belt (143).
7. Remove two set screws (169) and fan pulley (86).
8. Remove case drain tube (251).
9. Remove elbow (182).
10. Loosen screw (184) and remove pressure control guard (63).
11. Loosen set screw (102) and remove remote pressure control cable (12).
12. Remove eight screws (184) and washers (101), reservoir cover (237), filter assembly (A) and gasket (85).
13. Remove four screws (215) and o-rings (178), o-ring (180) and hydraulic pump (252) from reservoir cover (237).

Installation

1. Install hydraulic pump (252) on reservoir cover (237) with four screws (215) and o-rings (178), o-ring (180); torque 100 in-lb (11 N•m).
2. Install gasket (85) filter assembly (A) and reservoir cover (237) with eight washers (101) and screws (184); torque 90 in-lb (10 N•m).
3. Install elbow (182) per instructions, page 6; torque to 15 ft-lb (20.3 N•m).
4. Install pressure control guard (63) and tighten screw (184).
5. Connect hydraulic hoses (32) and (35).
6. Install case drain tube (251); torque to 15 ft-lb (20.3 N•m).
7. Install fan pulley (86) with two set screws (193).
8. Raise motor and install belt (143).
9. Install belt guard (24) with screw (224) and belt guard knob (241).
10. Install remote pressure control cable (12). Tighten set screw (102).
11. Install drain plug (195); torque to 110 in-lb (12.4 N•m). Install oil filter (199); tighten 3/4 turn after gasket contacts base. Fill with Graco hydraulic oil, page 7.
12. Start up and allow pump to operate at low pressure for approximately 5 minutes to purge all air.
13. Check and top off hydraulic oil level.

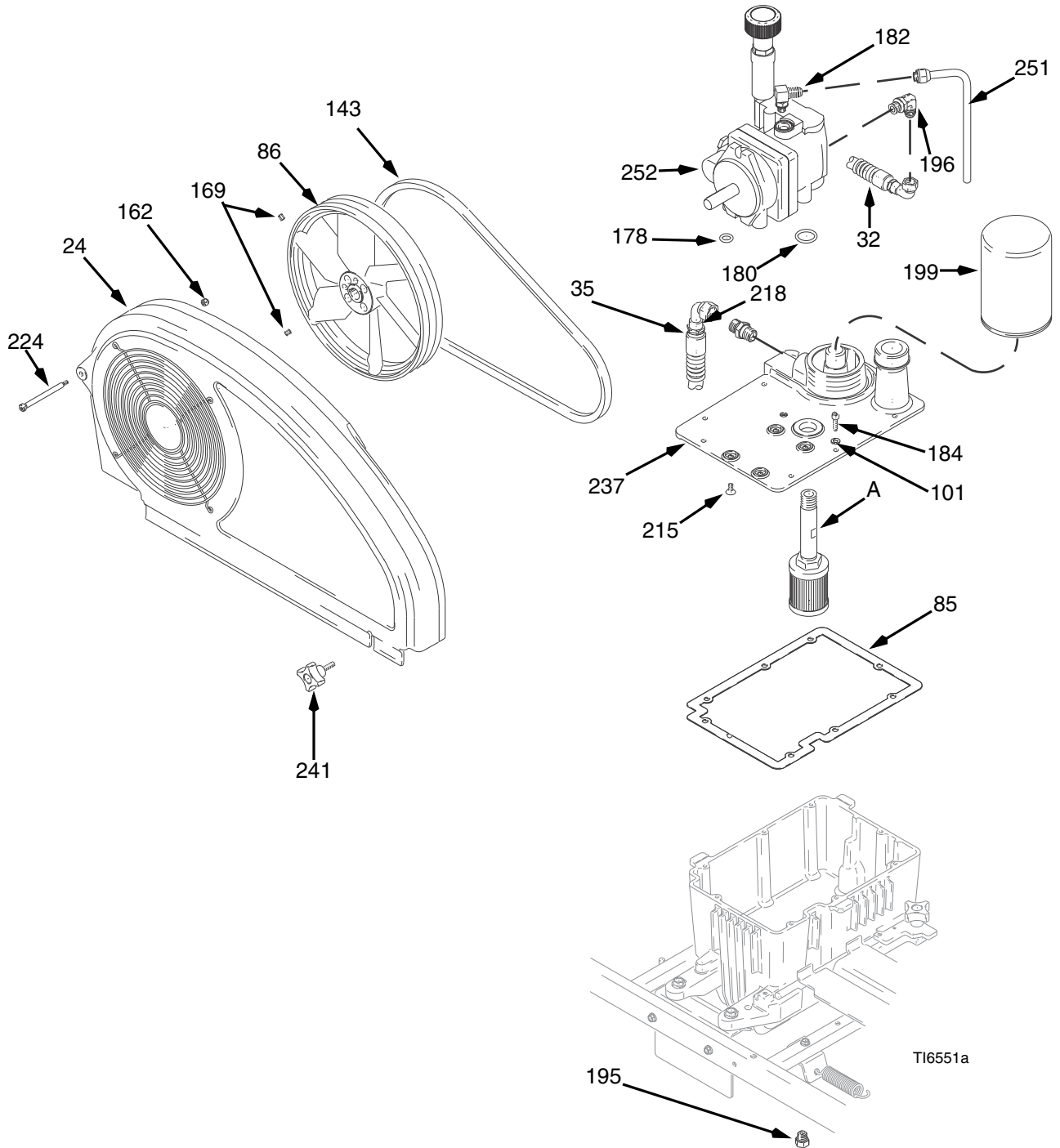

FIG. 2

Fan Belt

Removal



1. Relieve pressure, page 7.
2. FIG. 3. Loosen belt guard knob (241).
3. Rotate belt guard (24) up.
4. Lift engine (185) up to remove tension on belt (143).

5. Remove belt from fan pulley (86) and fan pulley (87a).

Installation

1. Thread belt (143) around fan pulley (87a) and fan pulley (86).
2. Lower engine (185) to put tension on belt.
3. Rotate belt guard (24) down.
4. Tighten belt guard knob (241).

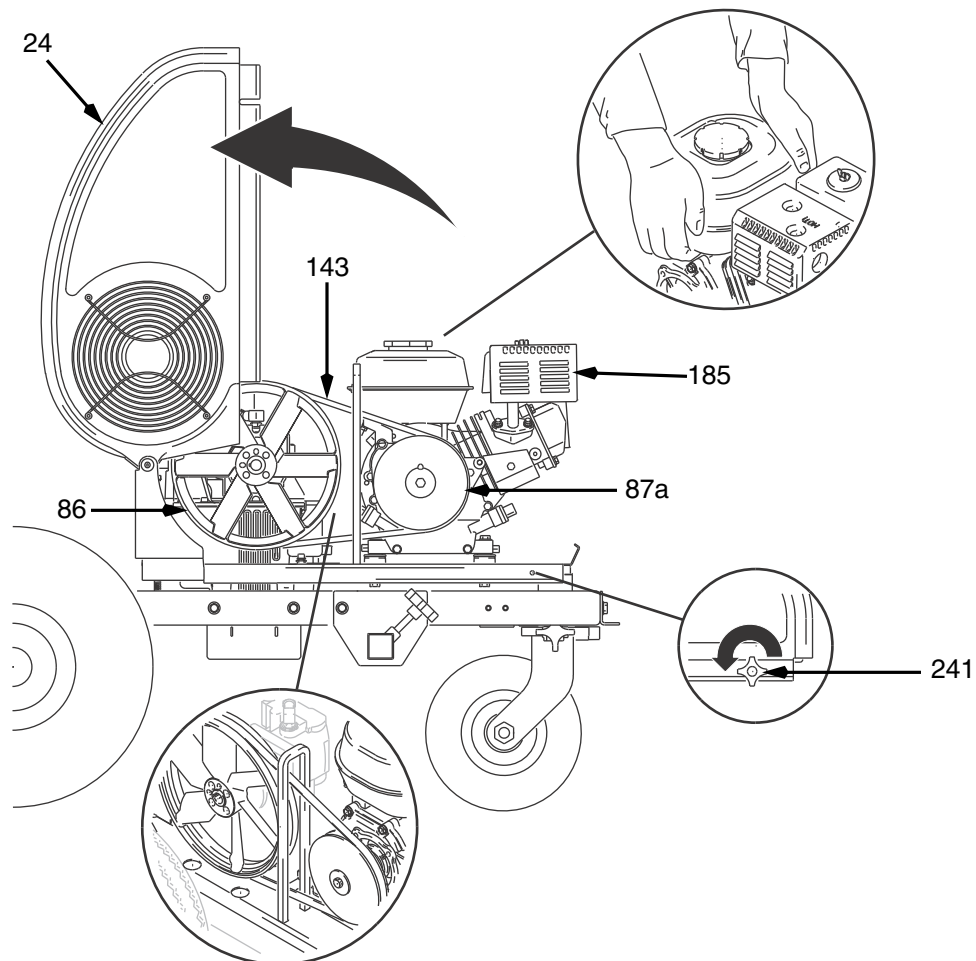

FIG. 3

T16511a

Engine

NOTE: All service to the engine must be performed by an authorized HONDA dealer,

Removal



1. Relieve pressure, page 7.
2. Do **Fan Belt, Removal**; page 13.
3. Loosen hand nut (241). Swing bracket (30) out.
4. FIG. 4. Disconnect red and black leads from engine.
5. Remove engine and rocker plate (87c) from sprayer.

6. Remove four screws (189), washers (114), washers (170) and nuts (118) and remove rocker plate, dampeners (59) and washers (114) from engine.

Installation

1. Install rocker plate (87c), dampeners (59) and washers (170), washers (114) on engine (185) with four screws (189), washers (170) and nuts (118); torque to 20 ft-lb (27.1 N•m).
2. Install engine and rocker plate (87c) on sprayer.
3. Connect red and black leads.
4. Do **Fan Belt, Installation**; page 13.
5. Swing motor retainer bracket (30) in. Tighten hand nut (241).

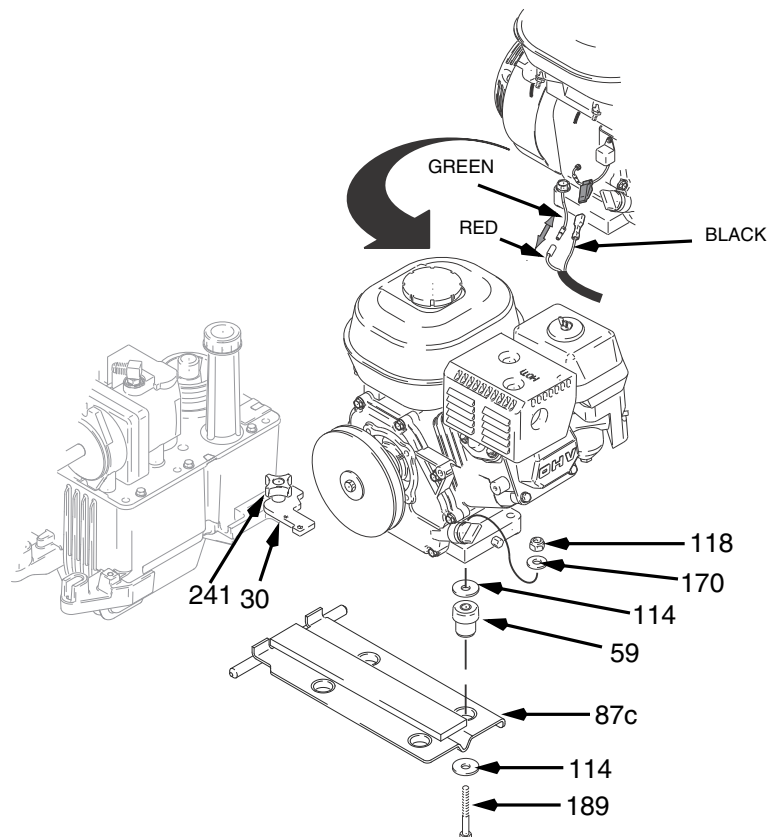

TI6520b

FIG. 4

Hydraulic Motor Yoke

Removal



1. Relieve pressure, page 7.
2. Place drip pan or rags under sprayer to catch hydraulic oil that leaks out during repair.
3. FIG. 5. Slide retainer clip (194) down to remove. Remove pump pin (249).
4. Remove hydraulic lines (35, 250) from fittings (217) at top left and right side of hydraulic motor.
5. Loosen jam nut (183).
6. Unscrew and remove hydraulic motor cap (25).
7. Slide piston rod/hydraulic motor cap assembly (A) from hydraulic motor cylinder (69).

Installation

1. Slide piston rod assembly (A) into hydraulic motor cylinder.
2. Screw down hydraulic motor cap (25) until cap bottoms out. Unscrew hydraulic motor cap until inlet and outlet align with hydraulic line fittings and test hole in hydraulic motor cap points toward belt guard (24).
3. Torque jam nut (183) against hydraulic motor cap (25) to 150 ft-lb (17 N•m).
4. Install hydraulic lines (35, 250) to fittings (217) to top left and right side of hydraulic motor per procedure on page 6; torque to 40 ft-lb (54.2 N•m).
5. Pull start rope slowly to align pin holes of hydraulic motor and displacement pump (21). Connect with pump pin (249); and retainer clip (194), page 18.
6. Start engine and operate pump for 30 seconds. Turn engine OFF. Check hydraulic oil level and fill with Graco hydraulic oil, page 7.

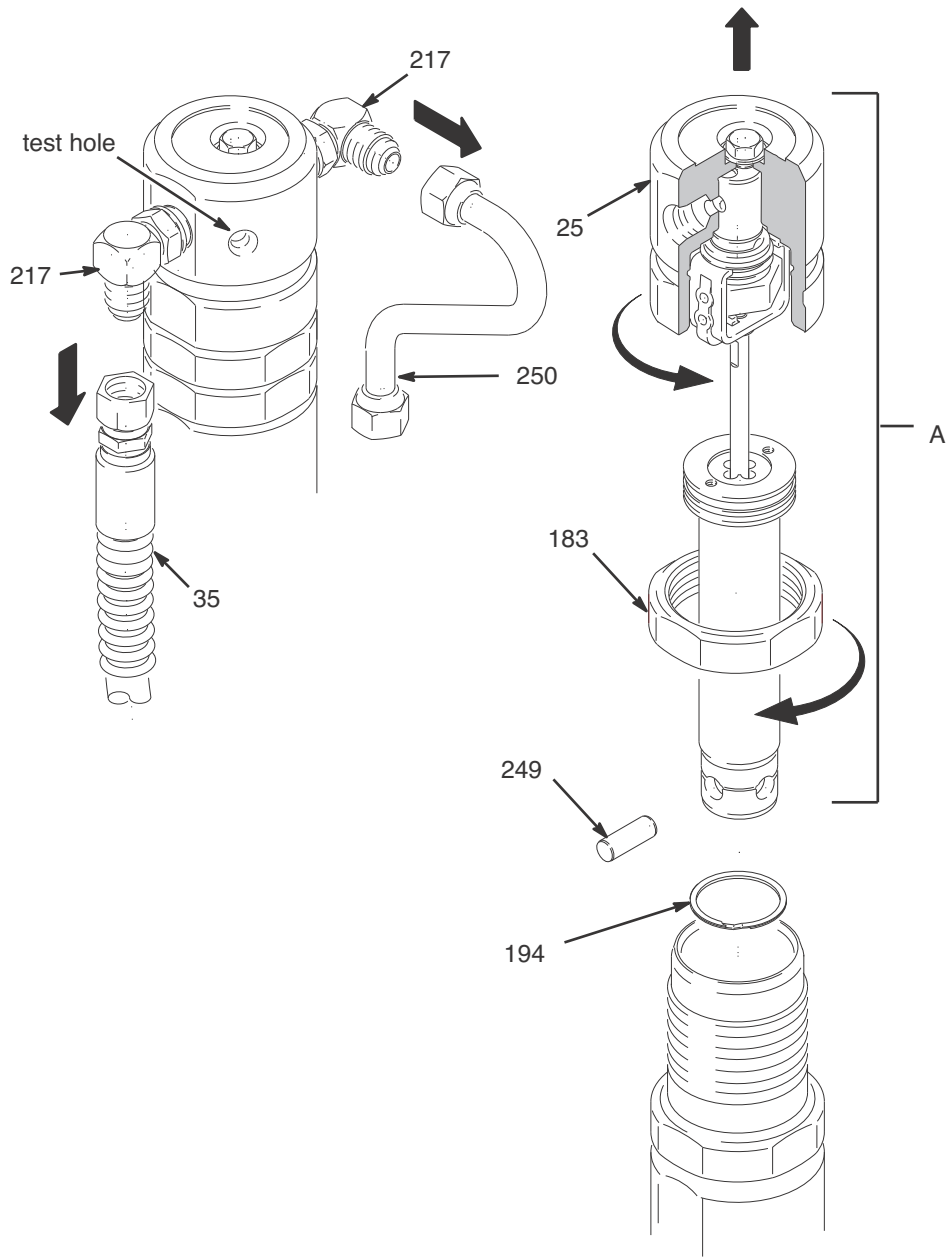

ti13918a

FIG. 5

Oil/Filter Change

Removal

1. FIG. 6 Place drip pan or rags under sprayer to catch hydraulic oil that drains out.
2. Remove drain plug (195). Allow hydraulic oil to drain.
3. Unscrew filter (199) slowly - oil runs into groove and drains out rear.

Installation

1. Install drain plug (195). Apply a light coat of oil to oil filter gasket and install oil filter (199). Tighten oil filter 3/4 turn after gasket contacts base.
2. Fill with 1.25 gallons (4.73 liters) of Graco hydraulic oil 169236 (5 gallon/20 liter) or 207428 (1 gallon/3.8 liter)
3. Check oil level.
4. Check oil level.

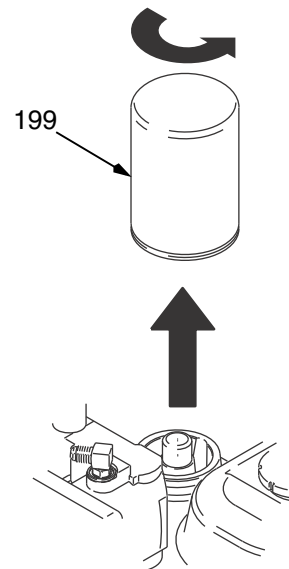

ti2271a

FIG. 6

Displacement Pump

See manual 311845 for pump repair instructions.

Removal

1. Flush pump.



2. Relieve pressure, page 7.
3. FIG. 7. Remove suction tube (34) and hose (26).

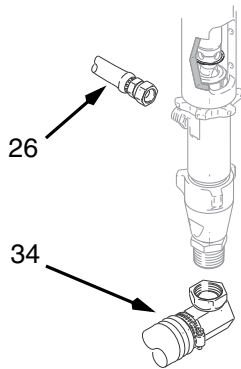

ti13904a

FIG. 7

4. FIG. 8. Push retaining spring (194) up. Push out pin (249).

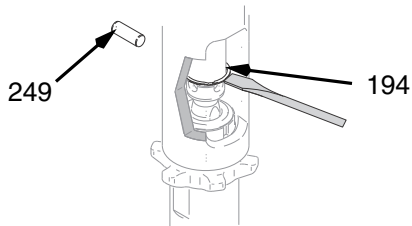

ti13905a

FIG. 8

5. FIG. 9. Loosen jam nut. Unscrew pump.

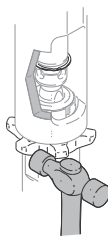

ti13906a

FIG. 9

Installation

CAUTION

If the pump jam nut loosens during operation, the threads of the hydraulic motor manifold will be damaged. Tighten jam nut as specified.

1. FIG. 10. Screw jam nut to bottom of pump threads. Screw pump completely into manifold. Unscrew pump from manifold until pump outlet aligns with hose. Hand tighten jam nut, then tap 1/8 to 1/4 turn with hammer or torque to 200 ft-lb (270 N•m).

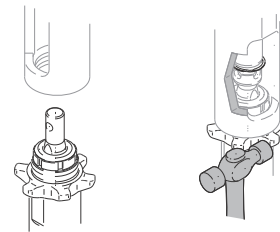

ti13907a

FIG. 10



2. FIG. 11. Slowly pull engine starter rope until pump rod pin hole is aligned with hydraulic rod hole. FIG. 8 Push pin (249) into hole. Push retaining spring (194) into groove.

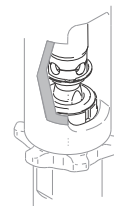

ti13908a

FIG. 11

3. FIG. 12. Fill packing nut with Graco TSL.

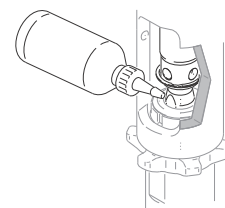

ti13809a

FIG. 12

Parts

LineLazer IV 130Hs

Parts Page 30

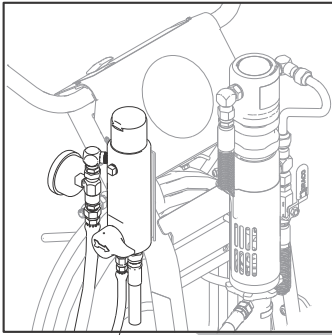

Parts Page 34

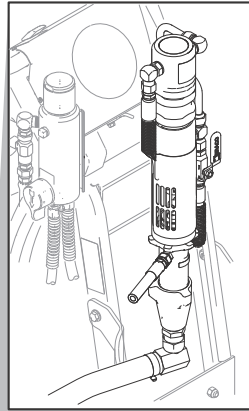

Parts Page 34

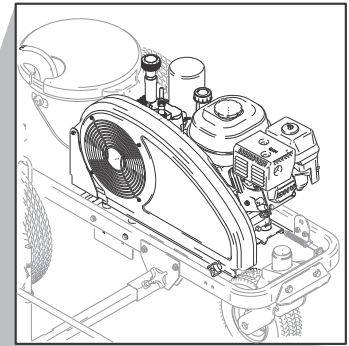

Parts Page 28

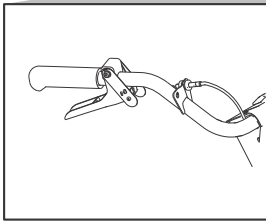

Parts Page 36

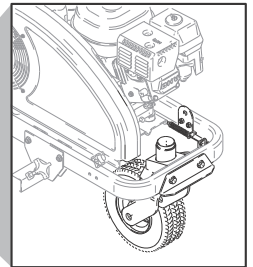

Parts Page 26

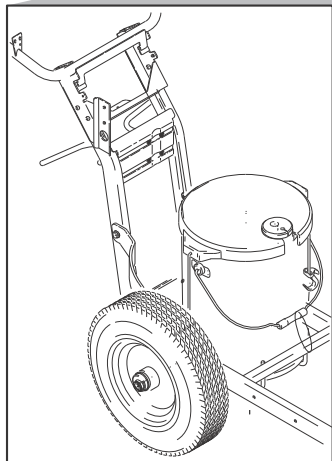

Parts Page 28

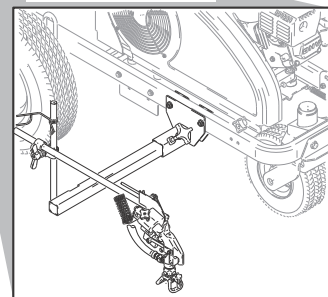

ti13917a

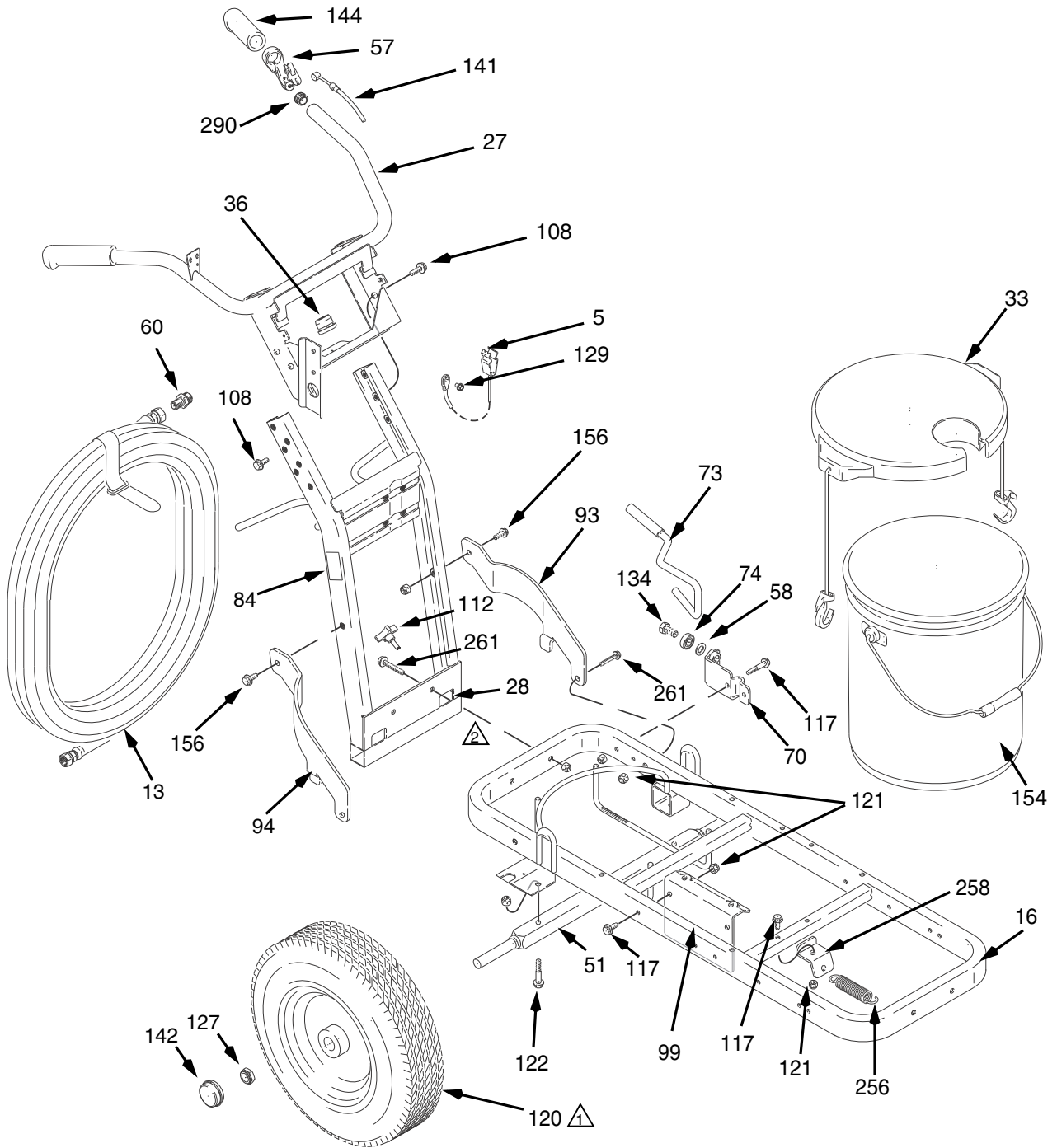

ti13910a

LineLazer IV 130HS

Ref	Part	Description	Qty
5	237686	CLAMP, grounding assy	1
13	245225	HOSE, 3/8 in. x 50 ft	1
16	287623	FRAME, linestriper (painted)	1
27	287417	HANDLE	1
28	287622	SUPPORT, handle, painted	1
33	287567	COVER, pail	1
36	115642	BUSHING, strain relief	2
51	193405	AXLE	1
57	194310	LEVER, actuator	1
58	195134	SPACER, ball guide	1
60	196176	ADAPTER, nipple	1
66	15K357	SENSOR, distance	1
68	15J088	SHIELD, sensor, distance	1
70	198891	BRACKET, mounting	1
73	198930	ROD, brake	1
74	198931	BEARING	1
77	114271	STRAP, retaining	1
84▲	15F638	LABEL, warning, fire and skin	1
93	15F577	BRACE, left, painted	1
94	15F576	BRACE, right, painted	1
99	15F425	BRACKET, reservoir	1
107	178342	CLIP, spring	4
108	112395	SCREW, cap	2
109	102478	STRAP, wiring tie (not shown)	6
51	193405	AXLE	1
112	111145	KNOB, pronged	2
117	110837	SCREW, flange, hex	10
120	255162	WHEEL, pneumatic	2
121	111040	NUT, lock, insert, nylock, 5/16	10
122	111194	SCREW, cap flange hd	2
127	112405	NUT, lock	4
129	112798	SCREW, thread forming, hex hd	2
134	113961	SCREW, cap, hex hd	1
141	241445	CABLE, caster	1
142	114648	CAP, dust	3
144	114659	GRIP, handle	2
154	115077	PAIL, plastic	1
156	112395	SCREW, cap, flng hd	2
256	119696	SPRING, extension	1
258	15F441	BRACKET, frame	1
261	116780	SCREW, hex hd	4
290	120151	PLUG, tube	2
134	113961	SCREW, cap, hex hd	1
141	241445	CABLE, caster	1

▲ Replacement warning labels may be ordered free of charge.

Notes

① Maintain tire pressure at 28-32 psi

② Torque to 17-23 ft-lb

LineLazer IV 130HS

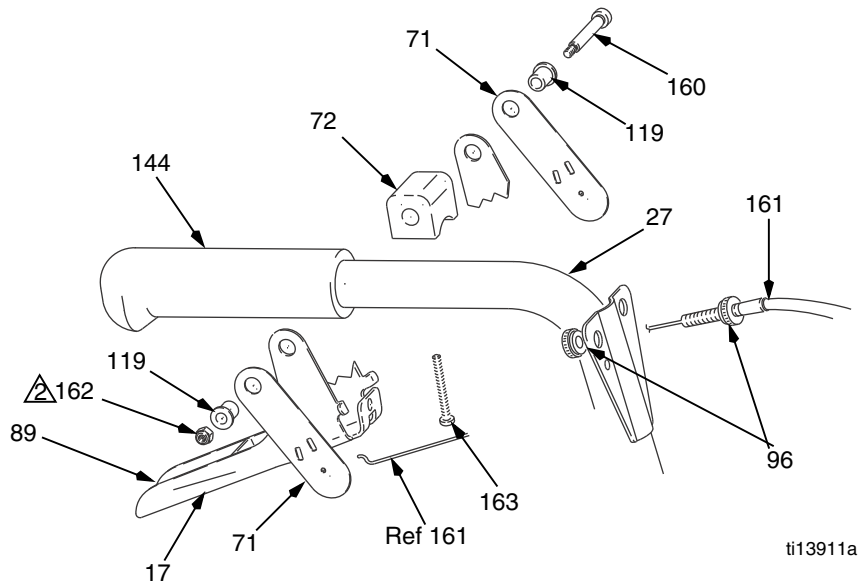
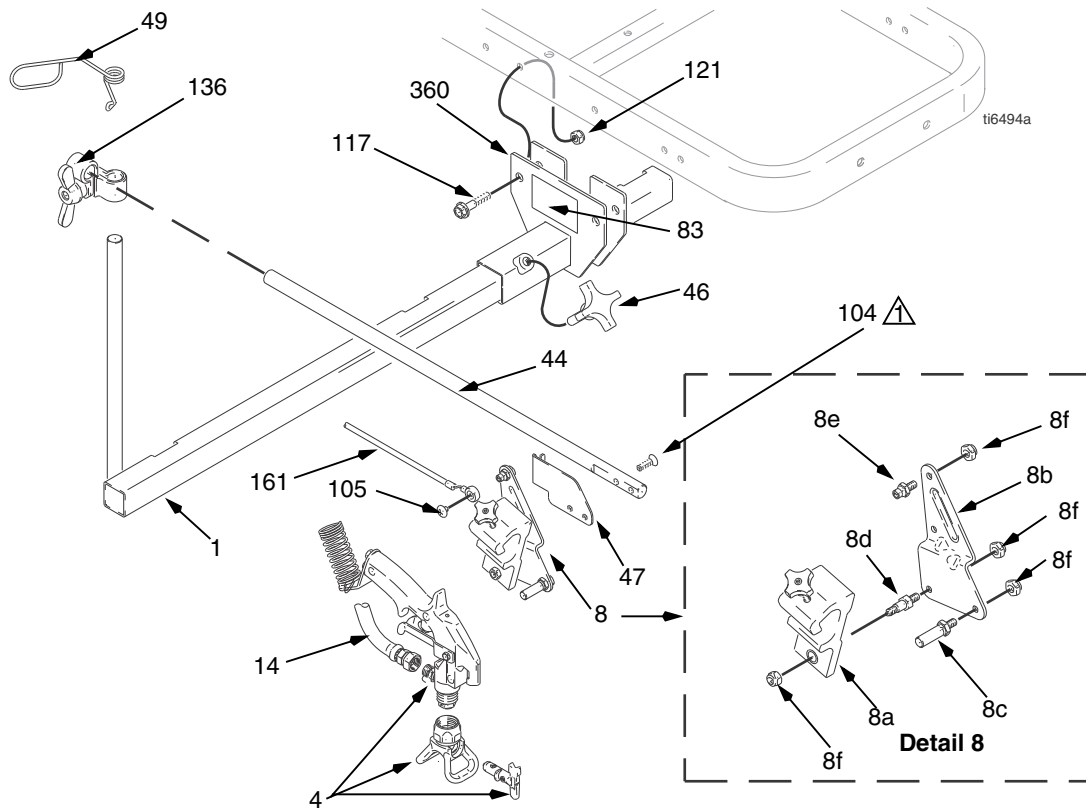

LineLazer IV 130HS

Ref	Part	Description	Qty
1	224052	BRACKET, support gun	1
4	248157	GUN, flex, basic, includes guard & tip	1
8	287570	KIT, holder, gun	1
8a	287569	HOLDER, gun	1
8b	15F214	LEVER, actuator	1
8c	15F209	STUD, pull, trigger	1
8d	15F210	STUD, pivot	1
8e	15F211	STUD, cable	1
8f	102040	NUT, lock	4
14	245798	HOSE, 1/4 x 7 ft	11
17	245733	KIT, trigger handle repair	1
27	287417	HANDLE	1
44	15F212	ARM, support	1
46	111145	KNOB, pronged	1
47	15F213	BRACKET, cable	1
49	188135	GUIDE, cable	1
71	198895	PLATE, lever, pivot	2
72	198896	BLOCK, mounting (mach)	1
83▲	15F637	LABEL, skin injection	1
89▲	15A644	LABEL, trigger	1
96	15F624	NUT, cable, gun	2
104	119647	SCREW, cap, socket, flthd	2
105	119648	SCREW, mach tursshhd, cross recess	1
109	102478	STRAP, wiring tie	6
117	110837	SCREW, flange, hex	2
119	111017	BEARING, flange	2
121	111040	NUT, lock	2
136	287566	KIT, clamp, includes 136a	1
144	114659	GRIP, handle	2
160	116941	SCREW, shoulder, socket head	1
161	287696	CABLE, includes 96	1
162	116969	NUT, lock	2
163	116973	SCREW, #10 taptite phil	1
360	15F389	BRACKET, gun arm	1

▲ Replacement warning labels may be ordered free of charge

Notes

① Torque to 90-110 in-lb

② Torque to 10-20 ft-lb

Parts - LineLazer IV 130Hs

(Engine Control Wiring Diagram)

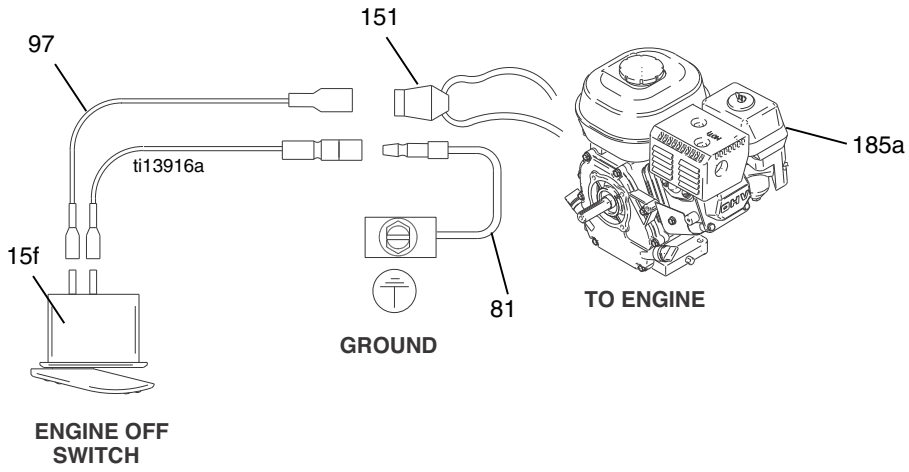

ENGINE OFF SWITCH

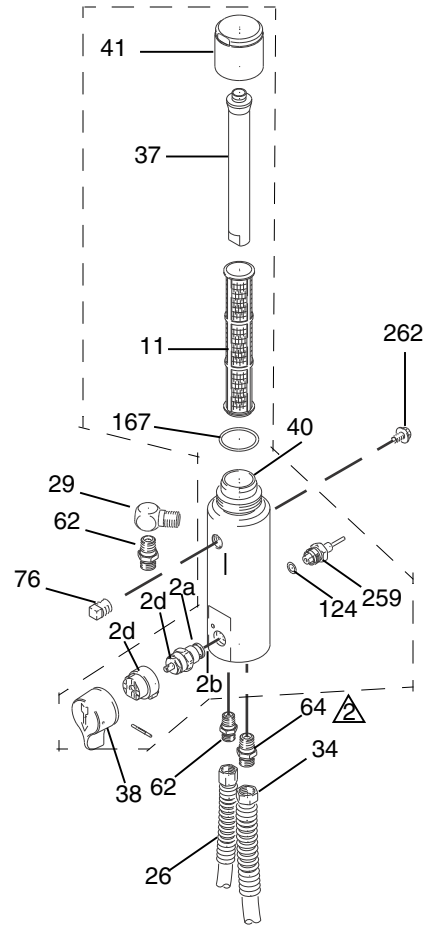
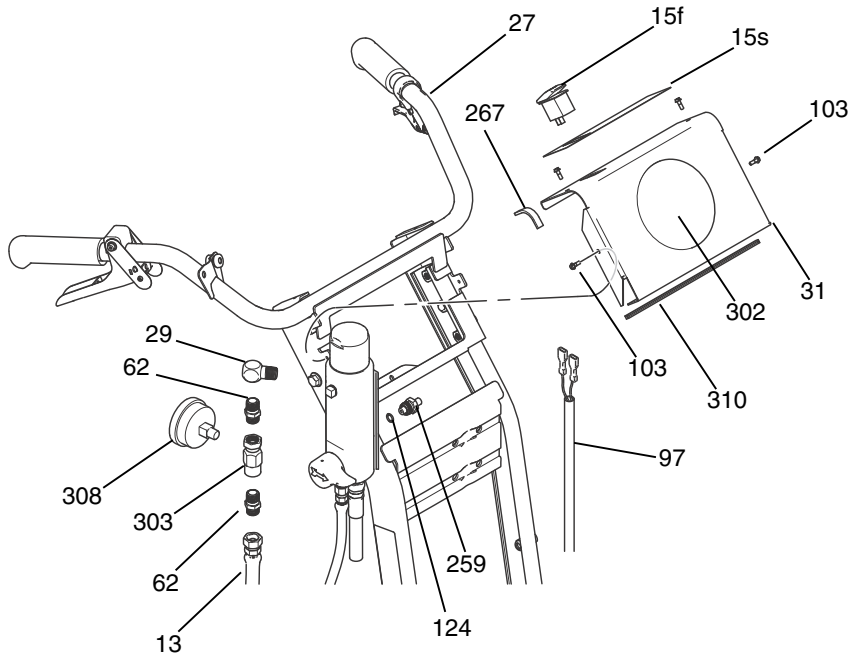



LineLazer IV 130Hs

Ref	Part	Description	Qty
2*	245103	VALVE, drain	1
2a	193709	SEAT, valve	1
2b	193710	SEAT, valve	1
2c	116424	NUT, cap	1
2d	114708	SPRING	1
11*	244067	FILTER, fluid	1
13	245225	HOSE, 3/8 in. x 50 ft	1
15f	114954	SWITCH, rocker	1
15s▲	15Y608	LABEL, control	1
26	245226	HOSE, coupled, 3/8 in.	1
27	287417	HANDLE	1
29	196179	FITTING, elbow, street	2
31	15Y465	COVER, control	1
34	287206	HOSE, suction/drain	1
37	15C766	TUBE, diffuser	1
38	15G563	HANDLE	1
40	15H561	MANIFOLD, filter, 3/8 npt	1
41	287285	KIT, repair, filter cap, includes 37, 167	1
62	196178	ADAPTER, nipple	2
64	196181	FITTING, nipple	1
76	104813	PLUG, pipe	1
97	122854	HARNESS, wiring	1
103	117501	SCREW	5
124	111457	O-RING	1
125	112303	SCREW, set, sch	1
167	117285	O-RING	1
259	15Y462	PLUG, filter	1
262	111801	SCREW, cap, hex	2
267	15F814	GASKET, handle	1
270	24B749	KIT, repair, filter, includes 2, 3, 11, 37, 38, 39, 40, 41, 124, 167, 259	1
302	15Y598	LABEL, brand	1
303	243683	ADAPTER (Model 257780)	1
308	115523	GAUGE (Model 257780)	1
310	123782	TRIM, rubber	1

▲ Replacement warning labels may be ordered free of charge

Notes

 Torque to 115-135 in-lb

 Torque to 130-150 ft-lb

Parts - LineLazer IV 130HS

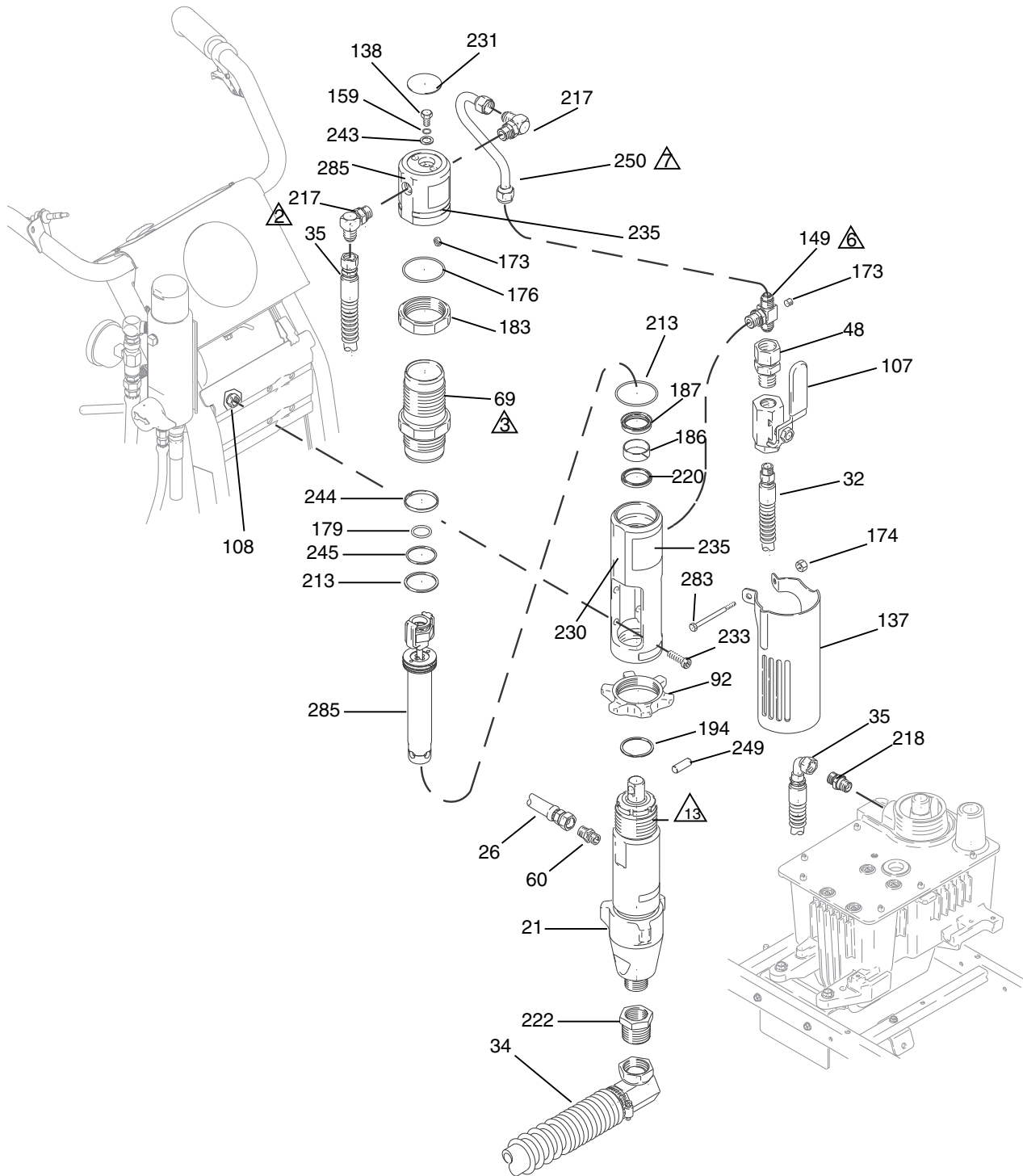



ti13914a

LineLazer IV 130Hs

Ref	Part	Description	Qty	Ref	Part	Description	Qty
21	24B748	PUMP, displacement Manual 311845	1	183	15A726	NUT, jam	1
26	245797	HOSE, coupled, 3/8 in.	1	186	112342	BEARING, rod	1
32	287175	HOSE, hydraulic, supply	1	187	112561	PACKING, block	1
34	287206	HOSE, suction/drain	1	194	116551	RING, retaining	1
35	287176	HOSE, hydraulic, return	1	213	117283	O-RING	1
48	117328	FITTING, nipple, straight	1	217	117607	FITTING, elbow, std thd	2
60	196178	ADAPTER, nipple 3/8 in. x 3/8 in.	1	218	117608	FITTING, nipple, straight	1
69	246176	SLEEVE, hydraulic cylinder, includes 213	1	220	117739	WIPER, rod	1
92	193031	NUT, retaining	1	222	15Y463	BUSHING	1
107	117441	VALVE, ball	1	230	15H953	MANIFOLD, adapter	1
108	101566	NUT, lock	4	231	15B063	LABEL,	1
137	15F911	GUARD, pump rod	1	233	107210	SCREW, cap, socket head	4
138	106276	SCREW, cap, hex hd	1	235	15B804	LABEL, Graco Logo	1
149	119841	FITTING, tee, branch, str thd	1	243	178179	WASHER, sealing	1
159	155685	O-RING	1	244	178207	BEARING, piston	1
173	100139	PLUG, pipe	1	245	178226	SEAL, piston	1
174	102040	NUT, lock, hex	2	249	197443	PIN, pump	1
176	105765	O-RING	1	250	15F519	TUBE, hydraulic, supply	1
179	108014	O-RING	1	283	110982	SCREW, cap, hex head	1
183	15A726	NUT, jam	1	284	288758	KIT, repair, hydraulic motor	1
186	112342	BEARING, rod	1	285	288735	KIT, repair, trip rod, piston	1
				KITS			
				246174 KIT, repair, seal, hydraulic, includes 176, 186, 213, 220, 244, 245			

Notes

 Torque to 75 ft-lb

 Torque to 85-95 in-lb

 Torque to 150 ft-lb

 Torque to 54-56 in-lb

 Torque to 40-44 ft-lb

 Torque to 40 ft-lb

 Torque to 25 ft-lb

LineLazer IV 130HS

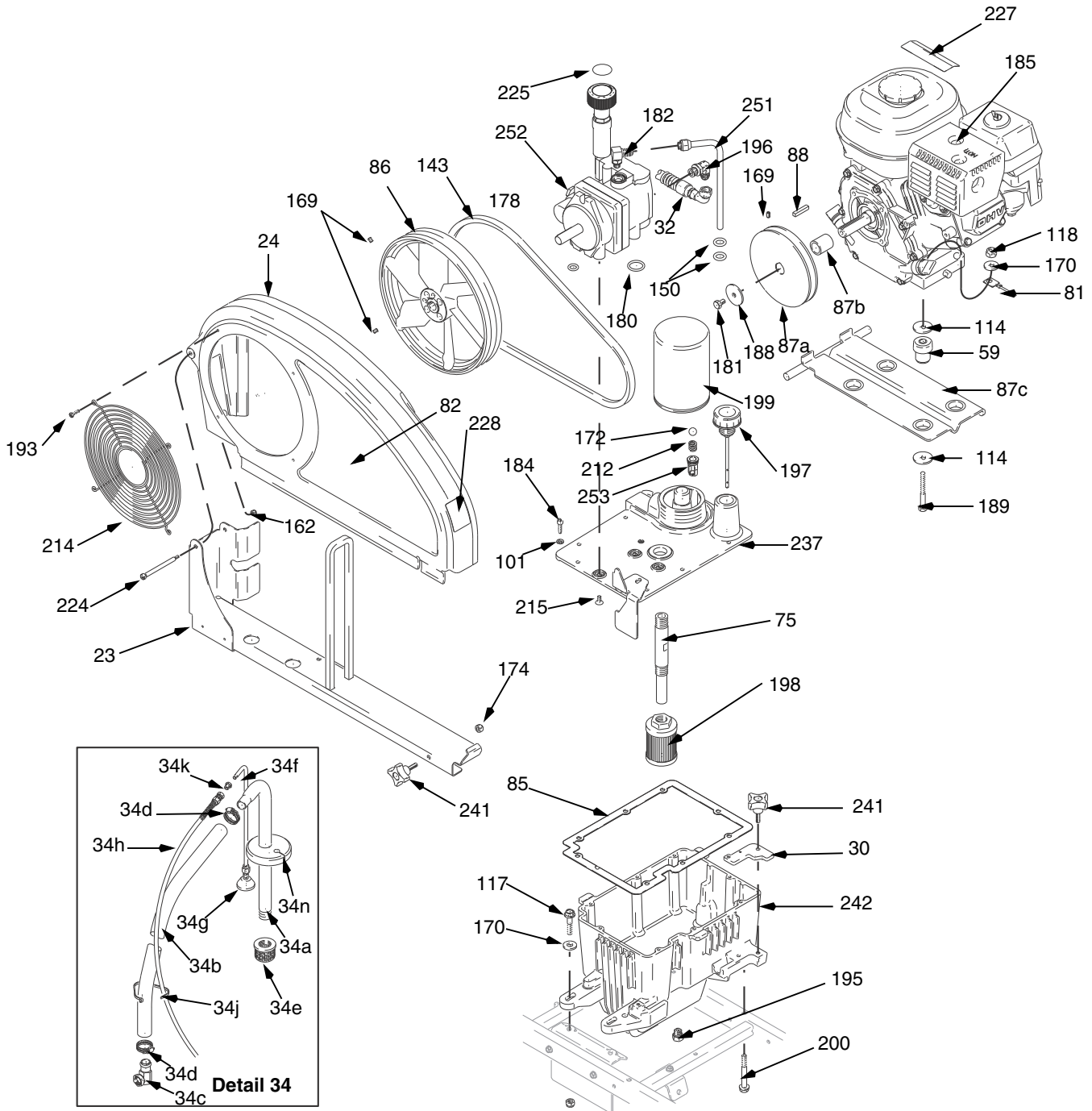

T16493b

LineLazer IV 130HS

Ref	Part	Description	Qty	Ref	Part	Description	Qty
23	288261	RAIL, belt	1	198	116919	FILTER, hydraulic, suction	1
24	248973	GUARD, belt, includes: 162, 193, 214, 224, and 228	1	199	246173	FILTER, oil, spin on	1
30	15E476	BRACKET, retainer, motor	1	200	120981	SCREW, hex wash hd	2
32	287175	HOSE, hydraulic supply	1	212	116967	SPRING, compression	1
34	287206	HOSE, suction/drain	1	214	117284	GRILL, fan guard	1
34a	15F149	TUBE, suction	1	215	117471	SCREW, 1/4-20 flat hd mach	4
34b	194306	HOSE, fluid	1	224	119434	SCREW, shoulder, socket head	1
34c	198119	ELBOW, barbed	1	225	15A464	LABEL, control	1
34d	101818	CLAMP, hose	1	227▲	194126	LABEL, warning	1
34e	181072	STRAINER, inlet	1	228▲	198492	LABEL, warning	1
34f	198601	TUBE, drain	1	237	15M057	COVER, reservoir, GH130 LL	1
34g	241920	DEFLECTOR, threaded	1	241	15D862	NUT, hand	2
34h	248008	HOSE, coupled 1/4 in. x 4 ft.	1	242	15J513	TANK, reservoir	1
34j	114958	STRAP, tie	7	251	246167	TUBE, hydraulic, case drain, includes: 150	1
34k	196180	BUSHING	1	252	288733	PUMP, hydraulic	1
34m	195119	LABEL, warning (not shown)	1	253	198841	RETAINER, ball, press bypass	1
34n	15F513	GASKET, pail	1				
59	15E888	DAMPENER, motor mount	4				
75	15E587	TUBE, suction	1				
81	240997	CONDUCTOR, ground	1				
82▲	15Y464	LABEL, brand 130HS	1				
85	120604	GASKET, reservoir	1				
86	15E410	PULLEY, fan	1				
87a	116908	PULLEY, 5.50 diameter	1				
87b	15E759	SPACER, shaft, engine	1				
87c	15F485	BRACKET, engine mount	1				
88	117632	KEY, square, 3/16 x 1.25	1				
101	100016	WASHER	8				
114	108851	WASHER, plain	8				
117	110837	SCREW, flange, hex	10				
118	110838	NUT, lock	4				
143	119433	BELT, vee, gripnotch	1				
150	154594	O-RING	2				
151	114956	TERMINAL, wire tap, insulated	1				
162	116969	NUT, lock	2				
169	100002	SCREW, set, sch	3				
170	100023	WASHER, flat	6				
172	100084	BALL, metallic	1				
174	102040	NUT, lock	1				
178	107188	O-RING	1				
180	156401	O-RING	1				
181	108842	SCREW, cap, hex head	1				
182	110792	ELBOW, male, 90 degree	1				
184	112166	SCREW, cap, sch	15				
185	248943	KIT, engine, gas, 5.5 hp, Honda, includes: 59, 87, 88, 98, 114, 118, 169, 170, 181, 185a, 188, 189, 227 and 234	1				
185a	120590	ENGINE, gas, 4.0 hp, Honda	1				
188	112717	WASHER,	1				
189	113664	SCREW, flange, hex	4				
193	115477	SCREW, mach, torx pan hd	4				
195	101754	PLUG, hex head, hydraulic	1				
196	116793	FITTING, elbow, hydraulic	1				
197	116915	CAP, breather filler	1				

▲ Replacement warning labels may be ordered free of charge

LineLazer IV 130HS

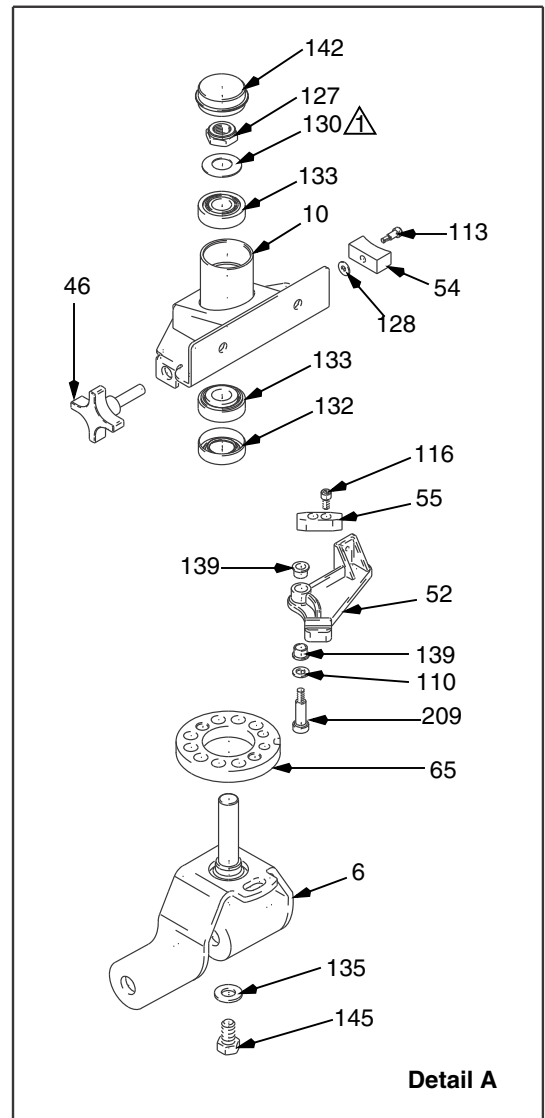
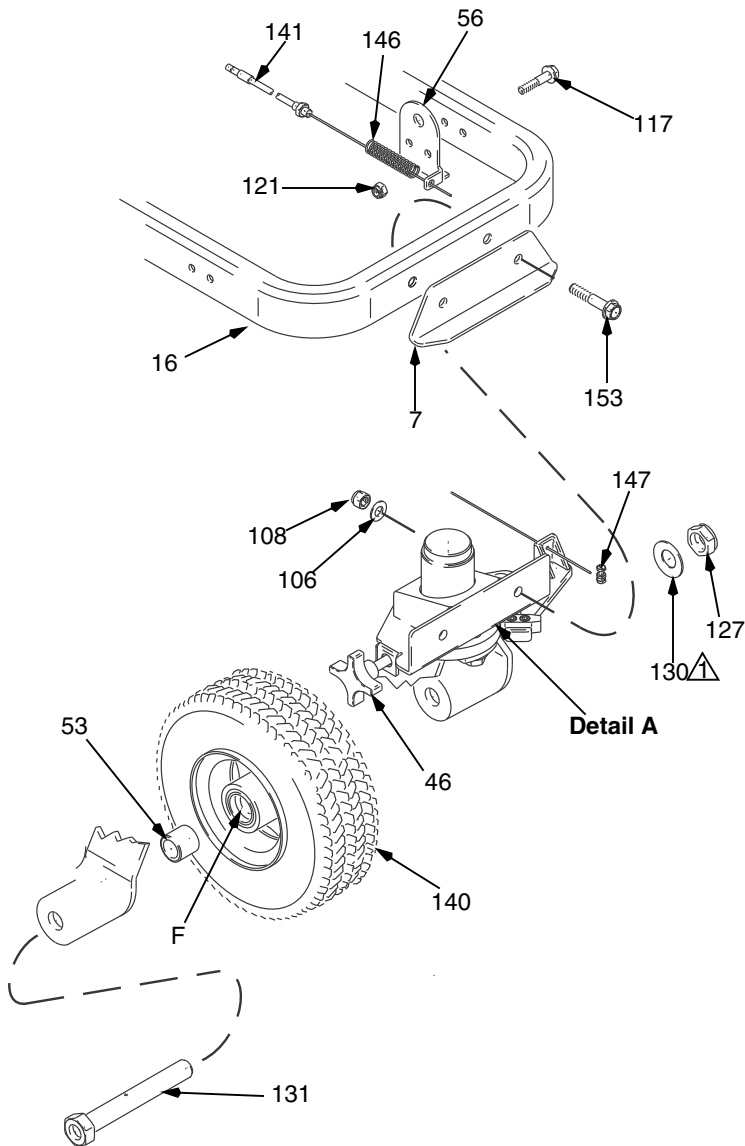

T16492b

LineLazer IV 130Hs

Ref	Part	Description	Qty	Ref	Part	Description	Qty
6	240942	SHAFT, fork	1				
7	240991	BRACKET, caster, front	1	128	112776	WASHER, plain	1
10*	15G952	BRACKET, hub	1	130	112825	SPRING, Belleville	3
16	287623	FRAME, linestriper, painted	1	131	113471	SCREW, cap, hex hd	
46	181818	KNOB, pronged	1	132*	113484	SEAL, grease	1
52	193528	ARM, detent	1	133*	113485	BEARING, cup/cone	2
53	193658	SPACER, seal	2	135	113962	WASHER, hardened	1
54	193661	JAW	2	139	114548	BEARING, bronze	2
55	193662	STOP, wedge	1	140	114549	WHEEL, pneumatic	1
56	15F910	BRACKET, cable	1	141	241445	CABLE	1
65	198606	DISK, adjuster	1	142	114648	CAP, dust	3
106	100731	WASHER	2	145	114681	SCREW, cap, hex hd	1
108	101566	NUT, lock	2	146	114682	SPRING, compression	1
110	15J603	WASHER, plain	1	147	114802	STOP, wire	1
113	108483	SCREW, shoulder, soc, hd	1	153	114982	SCREW, cap, flng, hd	2
116	110754	SCREW, flange, hex	10	154*	120476	BOLT	1
121	111040	NUT, lock	2				
127	112405	NUT, lock	4				

*Included in 240940 Bracket Repair Kit; purchase separately.

Notes

 Install washers (130) concave surface to inside

Technical Data

Honda GX160 Engine

Power Rating @ 3600 rpm	
ANSI	4.0 Horsepower
Maximum working pressure	3300 psi (227 bar, 22.7 MPa)
Noise Level	
Sound power	103 dBa, per ISO 3744
Sound pressure	88 dBa, measured at 3.1 feet (1 m)
*Vibration Level	
Left hand	2.90 m/sec ²
Right hand	2.83 m/sec ²
* Vibration measured per ISO 5349 based on 8 hour daily exposure	
Cycles/gallon (liter)	104 (27.5)
Maximum delivery	1.3 gpm (5.9 liter/min)
Maximum tip size	
1 gun	with 0.037 in. tip
Inlet paint strainer	16 mesh (1190 micron) stainless steel screen, reusable
Outlet paint strainer	60 mesh (250 micron) stainless steel screen, reusable
Pump inlet size	1 in. npsm(m)
Fluid outlet size	3/8 npt(f)
Hydraulic reservoir capacity	1.25 gallon (4.73 liters)
Hydraulic pressure	1510 psi (104 bar)
Weight (dry, without packaging)	242 lb (110 kg)
Height	40 in. (101.6 cm)
Length	65 in. (165.1 cm)
Width	32 in. (81.3 cm)
Wetted parts	PTFE, Nylon, polyurethane, V-Max™ UHMWPE polyethylene, fluoroelastomer, acetal, leather, tungsten carbide, stainless steel, chrome plating, nickel-plated carbon steel, ceramic

Accessories

Must be purchased separately.

GRACO-APPROVED HYDRAULIC OIL

169236	5 gallons (19 liters)
207428	1 gallon (3.8 liters)

Graco Standard Warranty

Graco warrants all equipment referenced in this document which is manufactured by Graco and bearing its name to be free from defects in material and workmanship on the date of sale to the original purchaser for use. With the exception of any special, extended, or limited warranty published by Graco, Graco will, for a period of twelve months from the date of sale, repair or replace any part of the equipment determined by Graco to be defective. This warranty applies only when the equipment is installed, operated and maintained in accordance with Graco's written recommendations.

This warranty does not cover, and Graco shall not be liable for general wear and tear, or any malfunction, damage or wear caused by faulty installation, misapplication, abrasion, corrosion, inadequate or improper maintenance, negligence, accident, tampering, or substitution of non-Graco component parts. Nor shall Graco be liable for malfunction, damage or wear caused by the incompatibility of Graco equipment with structures, accessories, equipment or materials not supplied by Graco, or the improper design, manufacture, installation, operation or maintenance of structures, accessories, equipment or materials not supplied by Graco.

This warranty is conditioned upon the prepaid return of the equipment claimed to be defective to an authorized Graco distributor for verification of the claimed defect. If the claimed defect is verified, Graco will repair or replace free of charge any defective parts. The equipment will be returned to the original purchaser transportation prepaid. If inspection of the equipment does not disclose any defect in material or workmanship, repairs will be made at a reasonable charge, which charges may include the costs of parts, labor, and transportation.

THIS WARRANTY IS EXCLUSIVE, AND IS IN LIEU OF ANY OTHER WARRANTIES, EXPRESS OR IMPLIED, INCLUDING BUT NOT LIMITED TO WARRANTY OF MERCHANTABILITY OR WARRANTY OF FITNESS FOR A PARTICULAR PURPOSE.

Graco's sole obligation and buyer's sole remedy for any breach of warranty shall be as set forth above. The buyer agrees that no other remedy (including, but not limited to, incidental or consequential damages for lost profits, lost sales, injury to person or property, or any other incidental or consequential loss) shall be available. Any action for breach of warranty must be brought within two (2) years of the date of sale.

GRACO MAKES NO WARRANTY, AND DISCLAIMS ALL IMPLIED WARRANTIES OF MERCHANTABILITY AND FITNESS FOR A PARTICULAR PURPOSE, IN CONNECTION WITH ACCESSORIES, EQUIPMENT, MATERIALS OR COMPONENTS SOLD BUT NOT MANUFACTURED BY GRACO. These items sold, but not manufactured by Graco (such as electric motors, switches, hose, etc.), are subject to the warranty, if any, of their manufacturer. Graco will provide purchaser with reasonable assistance in making any claim for breach of these warranties.

In no event will Graco be liable for indirect, incidental, special or consequential damages resulting from Graco supplying equipment hereunder, or the furnishing, performance, or use of any products or other goods sold hereto, whether due to a breach of contract, breach of warranty, the negligence of Graco, or otherwise.

FOR GRACO CANADA CUSTOMERS

The Parties acknowledge that they have required that the present document, as well as all documents, notices and legal proceedings entered into, given or instituted pursuant hereto or relating directly or indirectly hereto, be drawn up in English. Les parties reconnaissent avoir convenu que la rédaction du présente document sera en Anglais, ainsi que tous documents, avis et procédures judiciaires exécutés, donnés ou intentés, à la suite de ou en rapport, directement ou indirectement, avec les procédures concernées.

POUR LES CLIENTS DE GRACO PARLANT FRANCAIS

Les parties reconnaissent avoir convenu que la rédaction du présent document ainsi que de tous les documents, avis et procédures judiciaires exécutés, donnés ou intentés à la suite de ou en rapport, directement ou indirectement, avec les procédures concernées, sera en anglais.

ADDITIONAL WARRANTY COVERAGE

Graco does provide extended warranty and wear warranty for products described in the "Graco Contractor Equipment Warranty Program".

Graco Information

For the latest information about Graco products, visit www.graco.com.

TO PLACE AN ORDER, contact your Graco distributor or call 1-800-690-2894 to identify the nearest distributor.

All written and visual data contained in this document reflects the latest product information available at the time of publication. Graco reserves the right to make changes at any time without notice.

For patent information, see www.graco.com/patents.

Original instructions. This manual contains English. MM 313776

Graco Headquarters: Minneapolis
International Offices: Belgium, China, Japan, Korea

GRACO INC. AND SUBSIDIARIES • P.O. BOX 1441 • MINNEAPOLIS MN 55440-1441 • USA

Copyright 2007, Graco Inc. All Graco manufacturing locations are registered to ISO 9001.

www.graco.com
November 2012